



## Club Notes



**General Meeting:** Jan. 17th, 2017

Those with the last name that starts with M-P, please bring finger food for the meeting. General Meetings are the third Tuesday of the month at the church at 7:30 pm. You are invited and encouraged to attend! There is a silent auction and door prizes at every meeting.

**Next Board Meeting** The meeting will be January 9, 2017 at 7pm at the shop upstairs

**Next Show Meeting:** The show meeting will be Thursday 01/05/16 at the shop



### In This Issue:

- ❖ Club Notes
- ❖ General Information
- ❖ Meeting Minutes
  - Board Meeting
  - No meeting Dec. 2016
  - General Meeting
  - Dec.15th
- ❖ Rock Rumbles
- ❖ Announcements
- ❖ Show Schedules
- ❖ Field Trips
- ❖ Gem of the month
- ❖ Bench Tips by Brad Smith
- ❖ Kids Korner
- ❖ Shop Schedule
- ❖ Map To New General Meeting Place

**MGSCV Petrograph January 2017 2016**  
**Monthly Bulletin of the Mineral and Gem Society of Castro Valley, inc**

This publication is the bulletin of the Mineral and Gem Society of Castro Valley, Inc., a member of the California Federation of Mineralogical Societies, Inc., the American Federation of Mineralogical Societies and the North Bay Field Trip Association.

**Bulletin Submission Policy**

Submission deadline is the second Friday following the General Meeting (normally the second Wednesday of the month.) Anonymous contributions will not be considered for publication in the Petrograph; however, if requested at the time of submission, the contributor's name can be withheld. Members are encouraged to submit articles that may be of interest to the general membership. The bulletin editor reserves the right to edit any submitted articles or omit any submission from publication. Source must be cited for material quoted from other authors. Permission to reprint Petrograph articles is hereby granted provided properly cited.

**2015 MGSCV Officers**

**Elected**

President - Bonnie Andrade	<a href="mailto:President@mgscv.org">President@mgscv.org</a>	
Vice President - Neil Delfino	<a href="mailto:VP@mgscv.org">VP@mgscv.org</a>	
Secretary - Betty Milam	<a href="mailto:Secretary@mgscv.org">Secretary@mgscv.org</a>	(510) 589-8858
Treasurer - Sheryl Cooper	<a href="mailto:Treasurer@mgscv.org">Treasurer@mgscv.org</a>	
1 <sup>st</sup> Year Director - Michelle Bennette	<a href="mailto:Director1@mgscv.org">Director1@mgscv.org</a>	
2 <sup>nd</sup> Year Director - Jodi Minshall	<a href="mailto:Director2@mgscv.org">Director2@mgscv.org</a>	
3 <sup>rd</sup> Year Director - Norm Hodgson	<a href="mailto:Director3@mgscv.org">Director3@mgscv.org</a>	
Federation Director - Mike Mc Bride	<a href="mailto:Federation@mgscv.org">Federation@mgscv.org</a>	
Shop Manager - Beth Farmer	<a href="mailto:ShopManager@mgscv.org">ShopManager@mgscv.org</a>	
2014 Show Chairman - Cathy Miller	<a href="mailto:ShowChair@mgscv.org">ShowChair@mgscv.org</a>	
Membership - Tony Cooper	<a href="mailto:membership@mgscv.org">membership@mgscv.org</a>	510-589-5292
Editor - Peggy Lew	<a href="mailto:Editor@mgscv.org">Editor@mgscv.org</a>	650-464-7722
Past President - Ron Miller	<a href="mailto:pastpresident@mgscv.org">pastpresident@mgscv.org</a>	

**Appointed**

Scholarship Chair - Mary Howell	
Librarian - Mary Howell/ Mark Montgomery	
Historian - Norm Hodgson	
Purchasing Agent - Beth Farmer	
Education Coordinator - Shirley Buschke	
Field Trip Coordinator - Mike Cox	<a href="mailto:Mikecox.34ford@gmail.com">Mikecox.34ford@gmail.com</a>

Parliamentarian - Doc Buschke	
Reception/Host - Jim Ewing	
Sunshine Reporter - All members	
Door Prizes - Bonnie Andrade	
Web Master - Tony Cooper	<a href="mailto:webmaster@MGSCV.org">webmaster@MGSCV.org</a>



**Publication Staff**



## MGSCV Petrograph January 2017 2016

### Monthly Bulletin of the Mineral and Gem Society of Castro Valley, inc

✧Contributors: Shirley Buschke, Betty Milam, Sheryl Cooper, Mike McBride, Beth Farmer

#### BOARD MEETING

Submitted by **Sheryl Cooper**

There was no board meeting in December 2016. Too many members were unavailable during the month of December.

#### GENERAL MEETING

Submitted by **Sheryl Cooper**

GENERAL MEETING - December 10, 2016

#### The Annual MGSCV Christmas Party

The doors opened at noon and about 35 people attended this year's party. Thank you everyone for bringing something to share.

While the food was getting set up, **Bonnie Andrade** announced our Rockhounds of the year. Congratulations to **Doc** and **Shirley Buschke**. MGSCV Thanks you for your years of commitment, guidance and helping us in so many ways.



Everyone enjoyed a wonderful meal and desserts. The room was full of laughter and general talking while members caught up with each other.

**Mike McBride** let us know that **Mark Isaacs** won first place with his case at the CFMS show.

**Michelle Bennette** announced that we are now officially a **501c3 organization**.

All the while **Doc Buschke** was selling tickets for the turquoise tree raffle today. **Shirley Buschke** is healing nicely with a brace only on one wrist now. **Mark Montgomery** was running the silent auction. **Cathy Miller** told us the next show meeting is January 5th at the shop.

The show signup binder was ready for everyone to decide what positions they want for the 2017 show.

The raffle tickets for the opal pendent are printed. We have a total of 134 members for 2016.

The November minutes were approved by **Mark Montgomery** and seconded by **George Kozakura**.

The list for the 2017 Board is:

President - **Bonnie Andrade**

Vice President - **Neil Delfino**

Secretary - **Betty Milam**

Treasurer - **Sheryl Cooper**

Director - **Michelle Bennette**

Director - **Jodi Minshall**

Director - **Norm Hodgson**

Federation Director - **Mike McBride**

Shop Manager - **Beth Farmer**

Show Chair - **Cathy Miller**

Membership - **Tony Cooper**

Editor - **Peggy Lew** beginning Feb. 2017

Past President - **Ron Miller**

MGSCV Petrograph January 2017 2016

Monthly Bulletin of the Mineral and Gem Society of Castro Valley, inc

Voting will be at the January General meeting.

This year's beautifully wire wrapped turquoise tree was won by **Betty Milam**.



Congratulations!

The name drawn tonight for \$120 was **Roland Arajs** unfortunately he was not present. At the next meeting the amount goes to \$125

The silent auction wrapped up the party.

The next general meeting is on January 17, 2017



**ROCK RUMBLES**

By Shirley Buschke

**ROCK RUMBLES**

I am sorry we do not have anything this month as **Shirley Buschke** has been unable to get to the shop to talk to people and get the gossip.

**SHOW SCHEDULES**

**SAN GORGONIO MINERAL & GEM SOCIETY**

India, Ca

February 17-26; 10-10 daily

Riverside county fair & nat'l Date festival

82-503 Highway 111

Bert Grisham 915-849-1674

[Bert67@verison.net](mailto:Bert67@verison.net)

**ANTIOCH GEM CLUB**

Antioch, Ca

Contra Costa Fairgrounds

February 18-19; 10-5 daily

1201 West 10<sup>th</sup> st.

Brenda Miguel 925-301-6957

[Brenda.miguel@yahoo.com](mailto:Brenda.miguel@yahoo.com)

[www.antiochlapidaryclub.com](http://www.antiochlapidaryclub.com)

**VALLEJO GEM & MINERAL SOCIETY**

Vallejo, Ca

February 25-26<sup>th</sup>; 10-5pm daily

Solono county fairgrounds, Mc Cormack Hall

900 Fairgrounds Dr.

Dan Wolke 707-334-2950

[dnewolke@sbcglobal.net](mailto:dnewolke@sbcglobal.net)

[www.vjgems.org](http://www.vjgems.org)

**MGSCV Petrograph January 2017 2016**  
**Monthly Bulletin of the Mineral and Gem Society of Castro Valley, inc**



**GEM OF MONTH Jan. 2017**

**By Shirley Buschke**

Our gem was born in New Mexico and moved to Hayward, California when he was 5 years old. He graduated from Tennyson high school and went on to earn a degree from San Jose state University. He thinks he always was interested in rocks and became more so as his father became a vendor in the Bay Area. He worked with his dad, and was soon making jewelry on his own. He began working on a Master's Degree at Santa Clara University in counseling and went to work as a probation officer with the County of Santa Clara. His expertise was working with gangs, and he was a supervisor of his unit.

Our gem's favorite stone is turquoise but he likes many others too, it must be the New Mexico influence. Our gem often visits his mother who still lives in Hayward. Not so long ago he decided he wanted to make cabochons so he became one of Mark's students, and cut more than turquoise.

Our gem is married and has three children; two of them, a daughter and son are married.

Our gem said what started as a hobby has turned into a second career. He does southwestern designs in his jewelry as well as contemporary designs.

By now you must know who our gem is, he teaches soldering at our shop, and is a vendor at our show and many other club's shows. Of course you know Lee Chavez.

**ANNOUNCEMENT**

**Mark Issac** put in a case at the **CSMF** show and he won best in show. Congratulations **Mark!!!**

The shop will closed Wednesday, January 4<sup>th</sup> for plumbing repairs at the complex, if you plan on going Wednesday afternoon call ahead to find out if it is open

**BRAD SMITH BENCH TIPS**

**SANDING/POLISHING IN TIGHT PLACES**

Often you'll need to sand or polish an area that's impossible to reach with even a small wheel on a flexshaft. Other times it might be the bottom of a pocket or inside bottom corner of a box that needs to be finished. One trick for these nit-picky jobs may be left over from your last Chinese dinner - a chopstick.

I've found quite a few uses for these in the shop. Prepare the tip by simply sawing it off at a 45 degree angle. Then apply whatever abrasive grit you will need for the job or hold a strip of sandpaper around the end. Loose grit can be held onto the tip with a bit of vaseline or oil. Tripoli or rouge can be just rubbed onto the end of the chopstick.

**MGSCV Petrograph January 2017 2016**  
**Monthly Bulletin of the Mineral and Gem Society of Castro Valley, inc**



### OCHRE APPLICATOR

Yellow ochre is used when you want to be sure the solder won't flow on an area of your piece while you're soldering another area. The only problem with ochre is coming up with a good way to store and apply it.

I use recycled nail polish bottles. They seal well and have a built-in brush applicator. Just clean them out with a little acetone or nail polish remover, and they're ready to go.



See all Brad's jewelry books at  
[Amazon.com/author/BradfordSmith](https://www.amazon.com/author/BradfordSmith)

### KIDS KORNER

By: **Isabelle Bennette, 12 years old**

Indiana DeBeers: Raider of the Lost Diamond

By: Isabelle Bennette Age 12

Have you ever wondered why diamonds cost so much? Ever since the late 1800s, diamonds represented love, social status, and wealth. Its part in society has not changed much. There are thousands of other beautiful gems to choose from so why are diamonds considered to be the most valuable?

Through a process of securing diamond mines, collaborating with advertising groups, and supporting a cultural diamond revolution, DeBeers, a diamond tycoon company of the early 1900s, was able to transform diamonds into an expensive symbol of money and love. At first, people believed that diamonds were rare, as only members of royal families and rich merchants owned them. Because they were so uncommon and exclusive, prices were particularly high. And after the British financiers who had custody of the mines discovered an abundance of diamonds in Africa, they created the DeBeers company to maintain the high price. In order to make the most profit, DeBeers wanted to keep the novelty diamonds and appeal to the middle and lower classes. However, diamonds were also hard to sell at the time because the Great Depression was concurrent, so no one had enough money to buy a diamond. The Debeers co. needed the help of a successful advertising company in order to achieve their goals. Soon he developed a well-received commercial, making diamonds a symbol of love and associated with marriage through the introduction of the diamond engagement ring. This is how diamond rings became largely popular around the world. After the ad took off, celebrities and the media got involved, showing everyone how diamonds are essential to a great lifestyle. IGS said "the movie industry displayed its most glamorous women draped in diamonds. As a result, diamonds soon became a top status symbol for the rich and famous. This peaked with the **Marilyn Monroe** movie,

## MGSCV Petrograph January 2017 2016

### Monthly Bulletin of the Mineral and Gem Society of Castro Valley, inc

Diamonds are a Girl's Best Friend". Like many other trends, celebrities liked them, and the rest of the world followed.

This story has given me a different perspective upon diamonds and their role in society. Americans and other cultures' perception of mineral and gems are influenced by commercials, popular culture, and the media. Personally, it makes me thankful for the wider perspective I have gotten after being a member at MGSCV. It has given me the chance to learn about other gems and create my own opinion. For example, the majority of people, only know and like gems like diamonds because those are the only gems they are exposed to through the media. Being part of the club expands your knowledge on gem and minerals, and gives you the skills to examine other traits of stones. Many people don't know what tiger eye or amethyst, (my favorite rock), are, while these are two common things you will hear around the shop. Through our appreciation for all kinds of rocks, gems, and minerals, we have the ability to place value on the small details like color, pattern, and hardness. Society has shaped the views of the larger public, but the shop has given us unique knowledge that gives us an advantage.

#### **GEM OF THE MONTH GARNET**

The garnet is a very durable gemstone (6.5-7.5 on the Mohs scale) found all over the world, including Wyoming, Czech Republic, Greece, Russian, Tanzania, Madagascar, Sri Lanka and India.

The folklore on garnet is extensive. Legend has it that the garnet can bring peace, prosperity and good health to the home. Some even called it the "Gem of

Faith," and it's believed that to those who wear it and do good, more good will come. (Conversely, it was also said to bring very bad fortune to those who commit bad acts while wearing it.)

The garnet also symbolized deep and lasting friendship. With that legend in mind, give a garnet to someone whose friendship you deeply value.

No matter why or how you wear garnet, this beautiful gemstone is perfect for those who share January birthdays and get to start each New Year with a sense of goodwill, happiness, and purpose.



I hate to say this but Peggy Lew will be taking over for me as the editor of the Petrograph starting next month. I work a lot of hours and find it difficult to find time to work on it properly. I have greatly enjoyed being the editor and maybe sometime in the future when retired I will be able to do more.

Thank You

Diana Cohoon, Editor

**MGSCV Petrograph January 2017 2016**  
**Monthly Bulletin of the Mineral and Gem Society of Castro Valley, inc**  
**Shop Schedule**  
**(All shop session's members only)**

**MAP**

- Monday** 10 AM to 1 PM, Lapidary  
 6 PM to 9 PM, Beginners only in lapidary
- Tuesday** 12-to 5 PM, need daytime supervisor  
 6 PM to 9:00 PM, Lapidary,
- Wednesday** 9AM to 12:00PM, Lapidary  
 Library open 10AM to noon.  
 5:30 - 8:00 PM Lapidary
- Thursday** 10:00 AM to 1:00 PM, Lapidary  
 7 PM to 9 PM, Lapidary
- Friday** 9-1 PM Lapidary, Faceting (experienced only)
- Saturday** 9 AM to 3 PM, Faceting Class 9-12, Juniors,  
 w/supervisor's approval, lapidary  
 Library open 10AM to noon.
- Sunday** 9:30AM to 12:30 PM, Lapidary



**SHOP NOTICES:**

Email us at [info@mgs](mailto:info@mgs)



**MGSCV Petrograph January 2017 2016**  
**Monthly Bulletin of the Mineral and Gem Society of Castro Valley, inc**

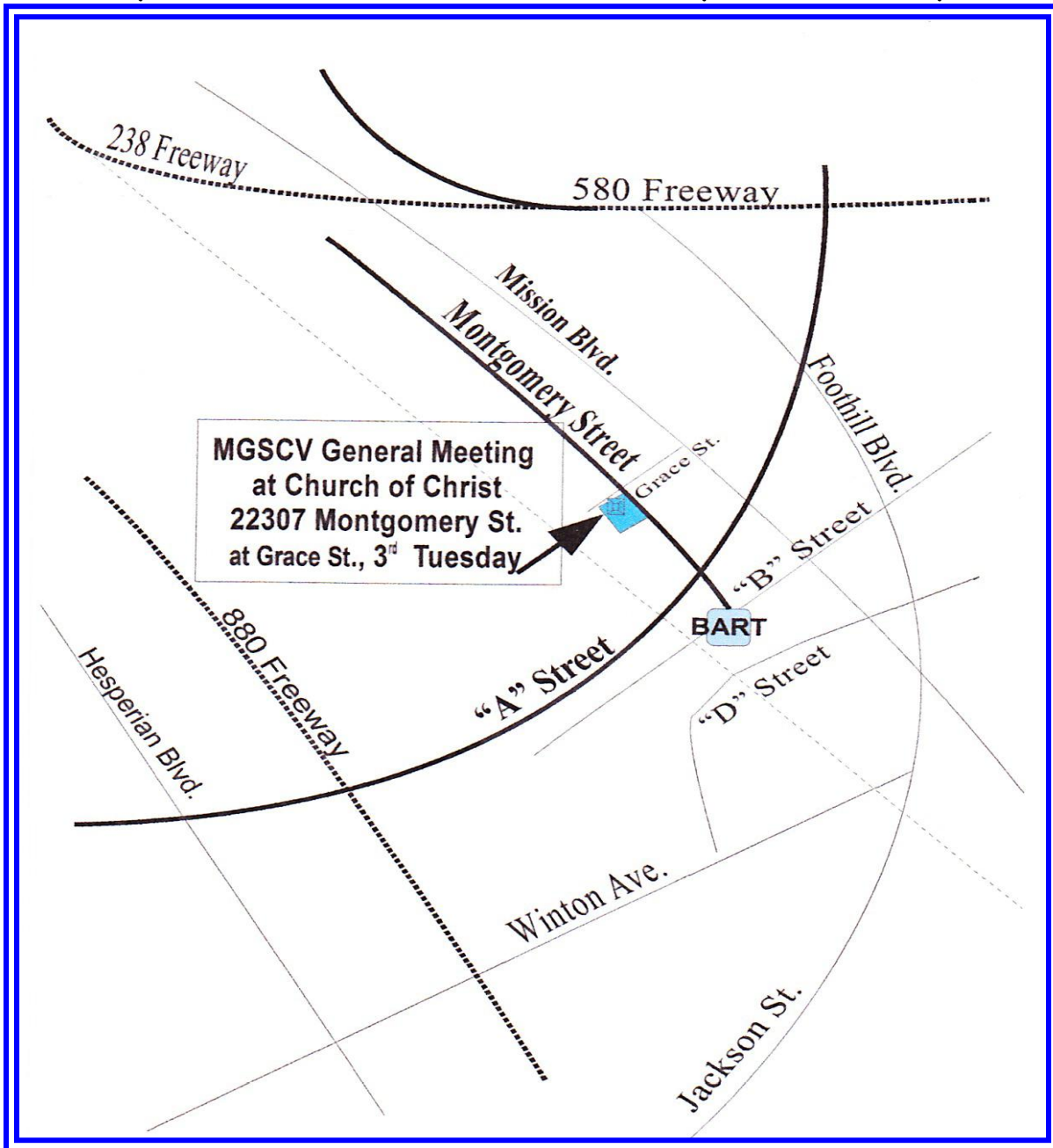

**From I 580: Take the A Street exit and go west, turn right on Montgomery Street and go to 22307 Montgomery Street.**

**From I 880: Take the A Street exit and go East. Turn left on Montgomery Street and go to 22307 Montgomery.**

**From Jackson Street: Go north on Mission Boulevard, turn left onto A Street, then right on Montgomery Street and go to 22307 Montgomery Street.**

# MGSCV Petrograph January 2017 2016

## Monthly Bulletin of the Mineral and Gem Society of Castro Valley, inc Mineral & Gem Society of Castro Valley (MGSCV) Membership Application and Information



Membership is good for one calendar year from January 1st through December 31st. Please fill out and sign the application. Mail the completed form, a check for the dues **payable to MGSCV**, and a self-addressed, stamped envelope to - **MGSCV, Attn: Membership Chair, P.O. Box 2145, Castro Valley, CA 94546.**

Your membership is active upon receipt of your check and application. It will be processed and membership cards will be at the shop within 4 weeks. Your email will be added to the list for the Petrograph, our newsletter. Your name will be added to the roster in the lobby at the workshop and in the drawing at the general meetings for cash prizes, if present.

We are a non-profit club whose sole purpose is the education of lapidary arts and geological sciences for all who are interested. **No products produced in the shop can be sold for profit.** All members should have or be familiar with the MGSCV Handbook. A copy is available for review in the club's lobby or one can be emailed to you by sending a request to [info@mgscv.org](mailto:info@mgscv.org).

Before any member may operate any equipment or take any class they must have completed an orientation and their first cabochon. **To schedule an orientation send an email to [WorkShopManager@mgscv.org](mailto:WorkShopManager@mgscv.org) with your name, phone number, and a good time to call you.** During the orientation you will learn about the club and get a tour of the workshop. Monday evenings are reserved for beginners only.

Membership dues cover less than 10% of our annual operating costs. It is our annual show that funds the club, workshop and all activities. **\*A requirement of membership is that every member must work at the show for a minimum of 4 hours.** The show is always held the first full weekend of March, so mark your calendars. The show is fun to work and is the reason we have the best workshop/club in Northern California. Shop services such as rock sawing, casting, special classes (faceting, wire wrap, metal work, etc...) will not be available to members who do not work at the show.

Membership Chairperson

Type of Membership(s):  new membership  renewal membership  Lifetime (voted in by the board)

* With Shop privileges	Junior Membership	NO Shop Privileges
<input type="checkbox"/> Single - \$45	<input type="checkbox"/> Junior (11-17 with adult) - \$1	<input type="checkbox"/> Single - \$35
<input type="checkbox"/> Couple - \$80	<input type="checkbox"/> Junior (11-17 without adult) - \$5	<input type="checkbox"/> Couple - \$60

After July 1st all **new** membership dues are half (1/2)

Name(s) (Please print all the names.)

Adults: \_\_\_\_\_

Juniors: \_\_\_\_\_

Address: \_\_\_\_\_

City: \_\_\_\_\_ State: \_\_\_\_\_ Zip: \_\_\_\_\_ Phone Number: \_\_\_\_\_

E-mail Address: \_\_\_\_\_

(Our monthly newsletter, the Petrograph, will be emailed to this address.)

Occupational Skills: \_\_\_\_\_

(Sometimes we are in need of advice and/or help in regards to electrical, plumbing, mechanical, clerical or other skills.)

Confidentiality: (check all that apply) **I do not want** my \_\_\_\_\_ phone \_\_\_\_\_ email printed in the roster at the shop.

I agree with the By-laws and rules of the Mineral & Gem Society of Castro Valley (MGSCV).

Members Signatures: \_\_\_\_\_

**Mineral & Gem Society of Castro Valley (MGSCV)  
Membership Application and Information**

**MGSCV Petrograph January 2017 2016**  
**Monthly Bulletin of the Mineral and Gem Society of Castro Valley, inc**

An invitation to Members & friends of MGSCV  
Show & Exhibit application

\*\*\*Business cards or mention of personal business is not acceptable for display in any case in the show\*\*\*

Your

Name: \_\_\_\_\_

\_\_\_\_\_

Your

Address: \_\_\_\_\_

\_\_\_\_\_

City: \_\_\_\_\_

Phone:(\_\_\_\_) \_\_\_\_\_

Member of \_\_\_\_\_

I will exhibit \_\_\_\_\_ cases

Please indicate whether you will be entering this case in competition.

Exhibit Only \_\_\_\_\_ Competition \_\_\_\_\_

I have a case. Upright \_\_\_\_\_ Slant Front \_\_\_\_\_

Case Dimensions: H \_\_\_\_\_ W \_\_\_\_\_ D \_\_\_\_\_

I want to borrow a club case ( 4ft. Upright, no liners or risers) \_\_\_\_\_

Please describe the material to be exhibited. (carvings ,fossils, Jewelry, & Minerals etc.)

\_\_\_\_\_

24 hour Security will be provided; however MGSCV assumes no responsibility for any loss or damage to exhibitor's property. This form must be on file for all exhibitors for each individual show year. Contact: Norm Hodgson, Exhibit Chairman, P.O. Box 2665, Fremont, Ca 94536 or call 510-744-1564.

Your co-operation in returning this form **AS SOON AS POSSIBLE** indicating whether or not you will be exhibit, will be greatly appreciated.

The following page contains the dimensions for the case which will help you decide the size of the background cloth and how many pieces that you can put in without looking too crowded.

MGSCV Petrograph January 2017 2016  
Monthly Bulletin of the Mineral and Gem Society of Castro Valley, inc

Petrograph

Petrog

CLUB SHOW CASE

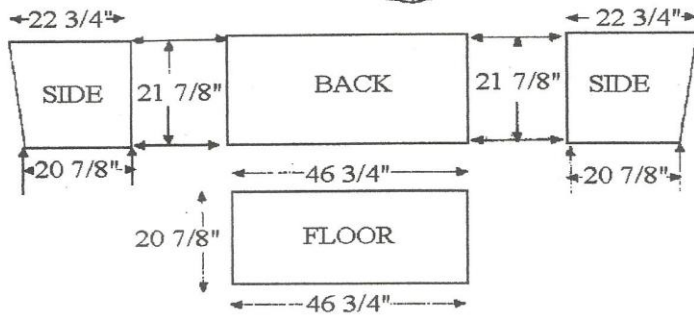
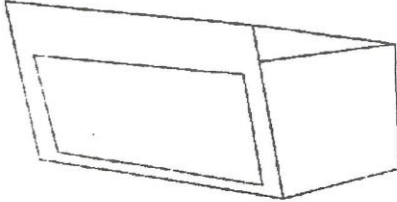

Dimensions Shown are Inside Dimensions